

# WLP-100 Wireless Power Transfer Installation Instruction

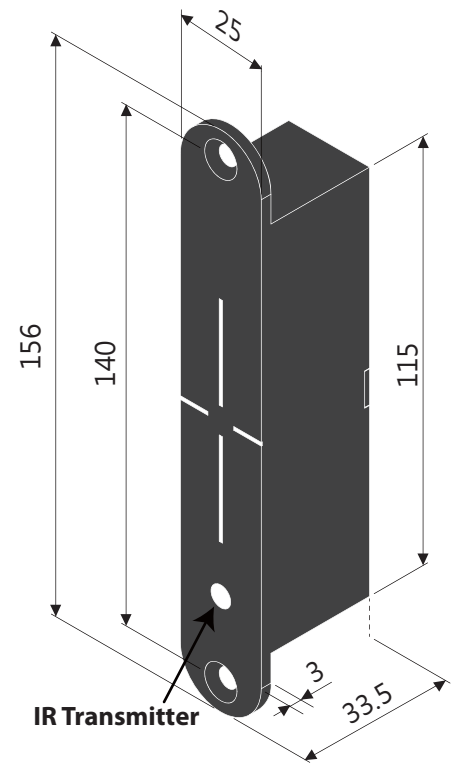

## Specifications

Transmitter on Frame Side	
Input Power	27.6 VDC or (24VAC)
Current Draw	1A/27.6VDC 1.3A/24VAC *Requires 1.5 A power when energized
Lock Status Output	Relay (Dry contacts: N.O./N.C./Com.) Rating: 3A/ 30VDC
Door Status Output	Reed Switch (Dry contacts: N.O./N.C./Com.) Rating: 0.1A/ 20VDC
Receiver on Door Side	
Output Power	12/24 VDC
Current Draw	800mA/12VDC 400mA/24VDC
Lock Status Input	Dry contacts: N.O./Com.
Infrared Sensing	Transmitter ⇔ Receiver
Door Opening Time	15 / 30 seconds *For fail-secure locks only
Maximum Door Gap	3/16" (4~5mm)
Maximum Tolerance with 3/16" (4~5mm) Door Gap	Horizontal alignment : 1/16" (1mm) Vertical alignment : 1/16" (1mm) IR Sensing: 1/16" (1mm)
Operating Temperature	32° to +120.2°F ( 0° to +49°C )
Humidity	0 to 85% Non-condensing

Unit: mm

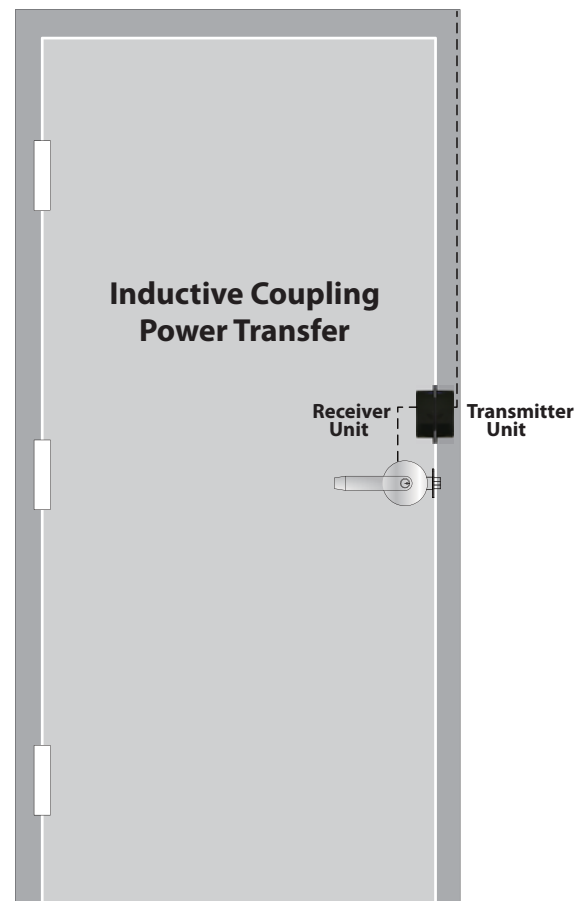

# Installation & Wiring

## Included in Package

- Door Side Unit
- Frame Side Unit
- Door Side Template
- Frame Side Template
- Wood Screws
- Metal Screws
- Mounting Tabs
- Washers

Note: For optimal performance, it is recommended to minimize the door gap and use the supplied templates. The WLP-100 allows for some horizontal and vertical misalignment. Tolerance for minor misalignment will increase as door gap decreases.

## Installation Steps

### 1. Door & Frame Inspection

After checking the door and frame conditions, apply the templates at the appropriate location. The WLP-100 can be installed on the latch side, hinge side, or top of the door.

1a. Apply the door side template.

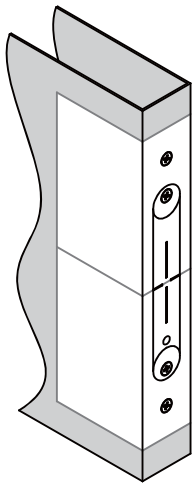

1b. Apply the frame side template. Make sure to align the horizontal and vertical centerlines.

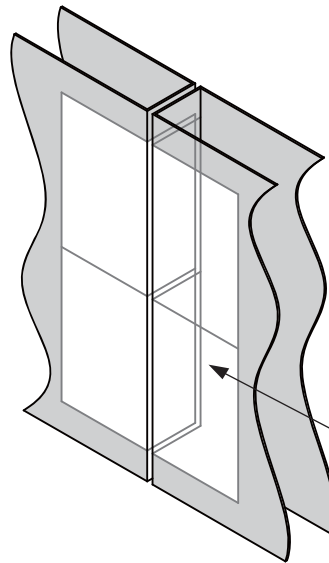

Align the centerline on the template.

### 2. Metal Door Installation

2a. Center punch the screw locations for mounting tabs and counter-sink for M5 screw.

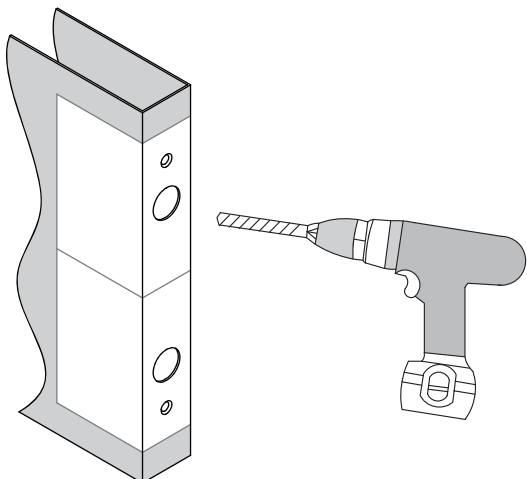

2b. Cut out the main body on the door.

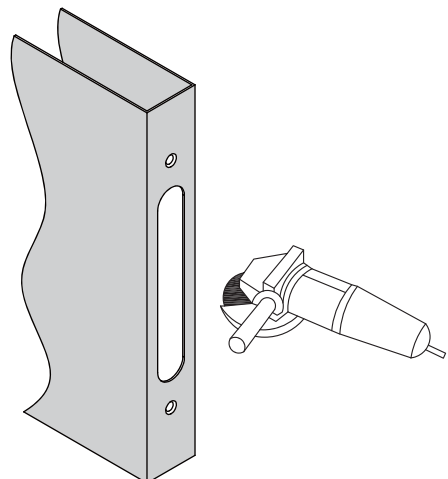

2c. Check if the WLP-100 fits well in the cutout and use the file if necessary.

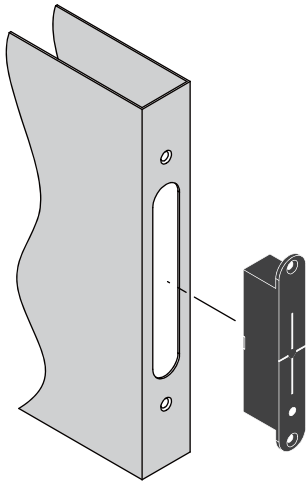

2d. Install mounting tabs using M5 screws.

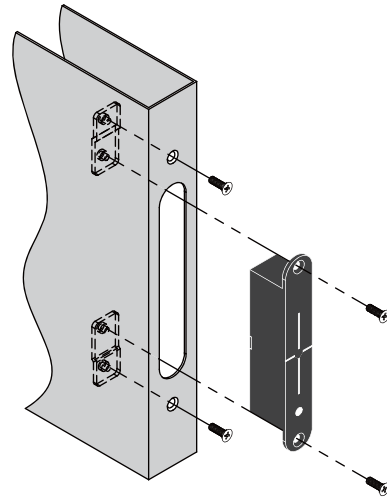

### 3. Wood Door Installation

3a. Drill two 1" (25mm) diameter holes, 1/8" (3mm) in depth as shown on the template.

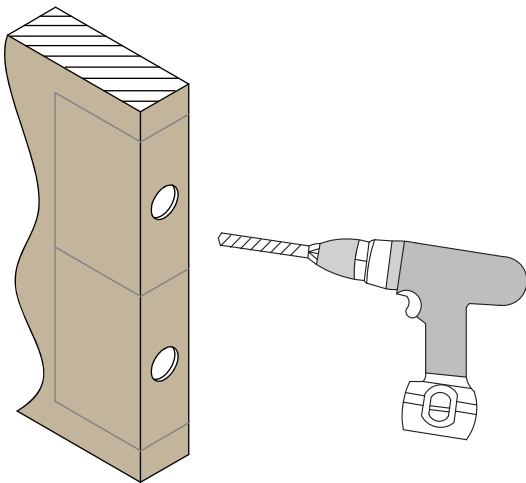

3b. Drill and cut the WLP-100 main body to a minimum depth of 1-9/16" (40mm), and diameter of 1" (25mm) on the door side.

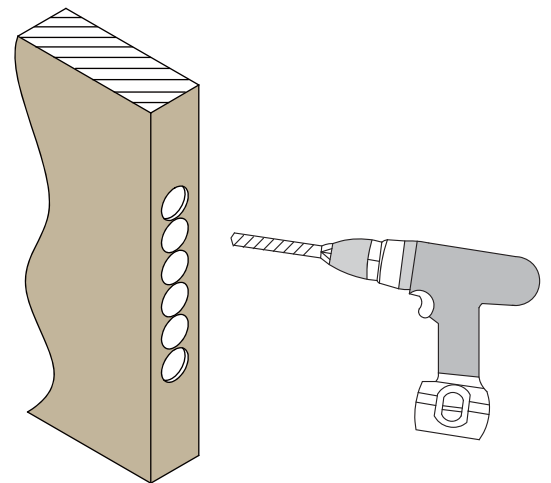

3c. Use the chisel to straighten the sides.

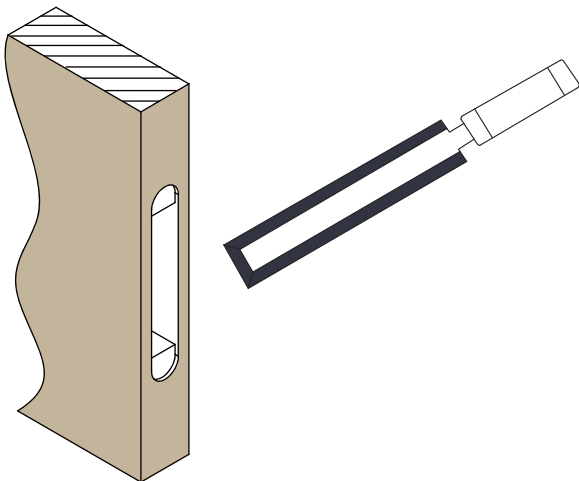

3d. Check if the WLP-100 fits well in the cutout and use the file if necessary.

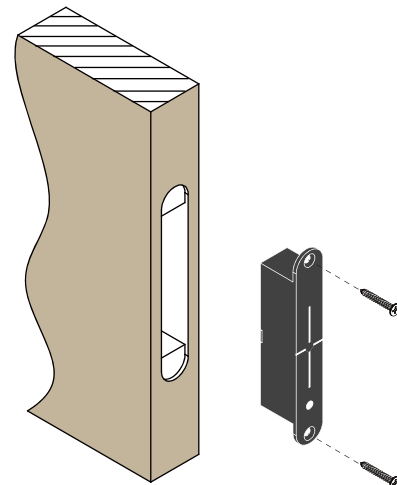

3e. For the door side unit, drill a wiring channel to the electrified device to be powered.

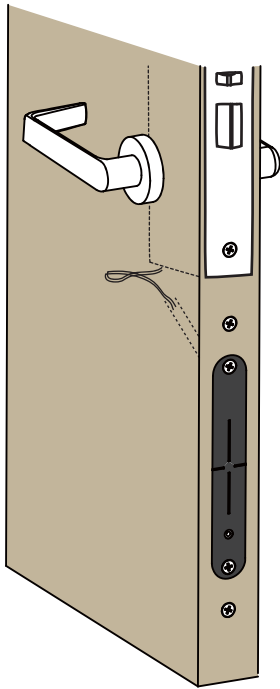

#### 4. Selecting the Lock Output Voltage

Use the jumper on the back of the door side unit to select the appropriate lock voltage.

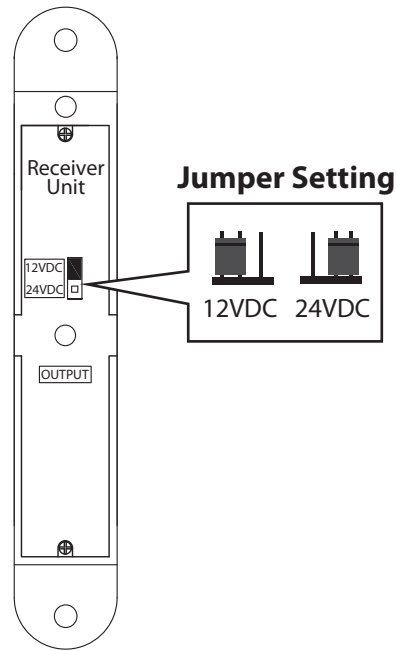

#### 5. Frame Installation

For the frame side unit, repeat steps 2 or 3 to install on a metal or wood frame.

#### Wiring Instructions

Please refer to the wiring diagrams on page 5, 6.

WLP-100	Pigtail	Wire Color	Function
	Input Power	Red (+)	27.6VDC / 1.5Amp 24VAC / 1.3Amp
		Black (-)	Ground
	Reed Switch	Red	N.C.
		Black	COM.
		White	N.O.
	Relay Output (Lock Status)	Yellow	N.C.
		Green	COM.
		Blue	N.O.
		Lock Status Input	Blue
Green			COM.
Lock Power Output		Red (+)	12 or 24VDC (select through jumper setting)
		Black (-)	

# WLP-100 Wiring Diagram (1)

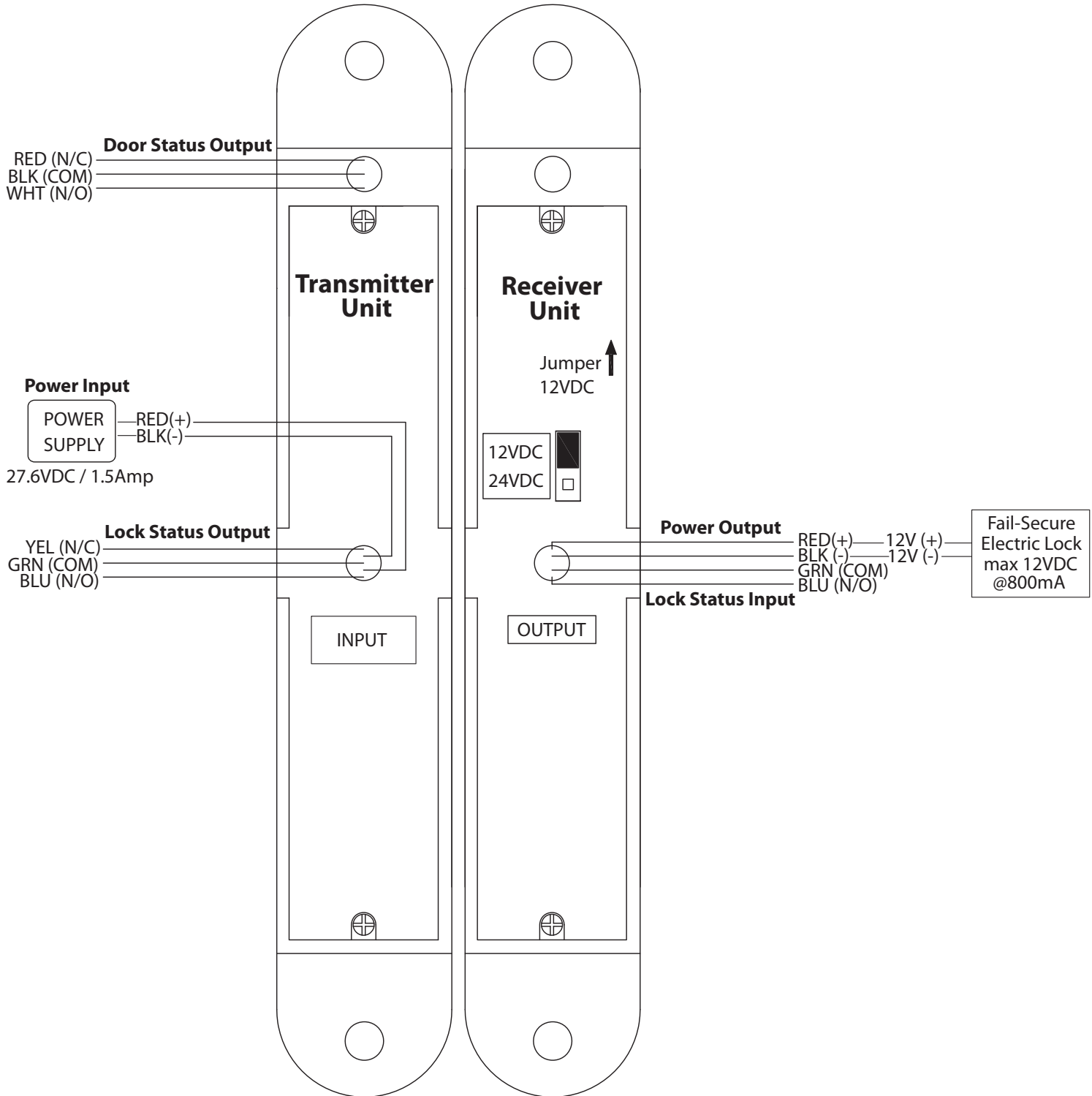

# WLP-100 Wiring Diagram (2)

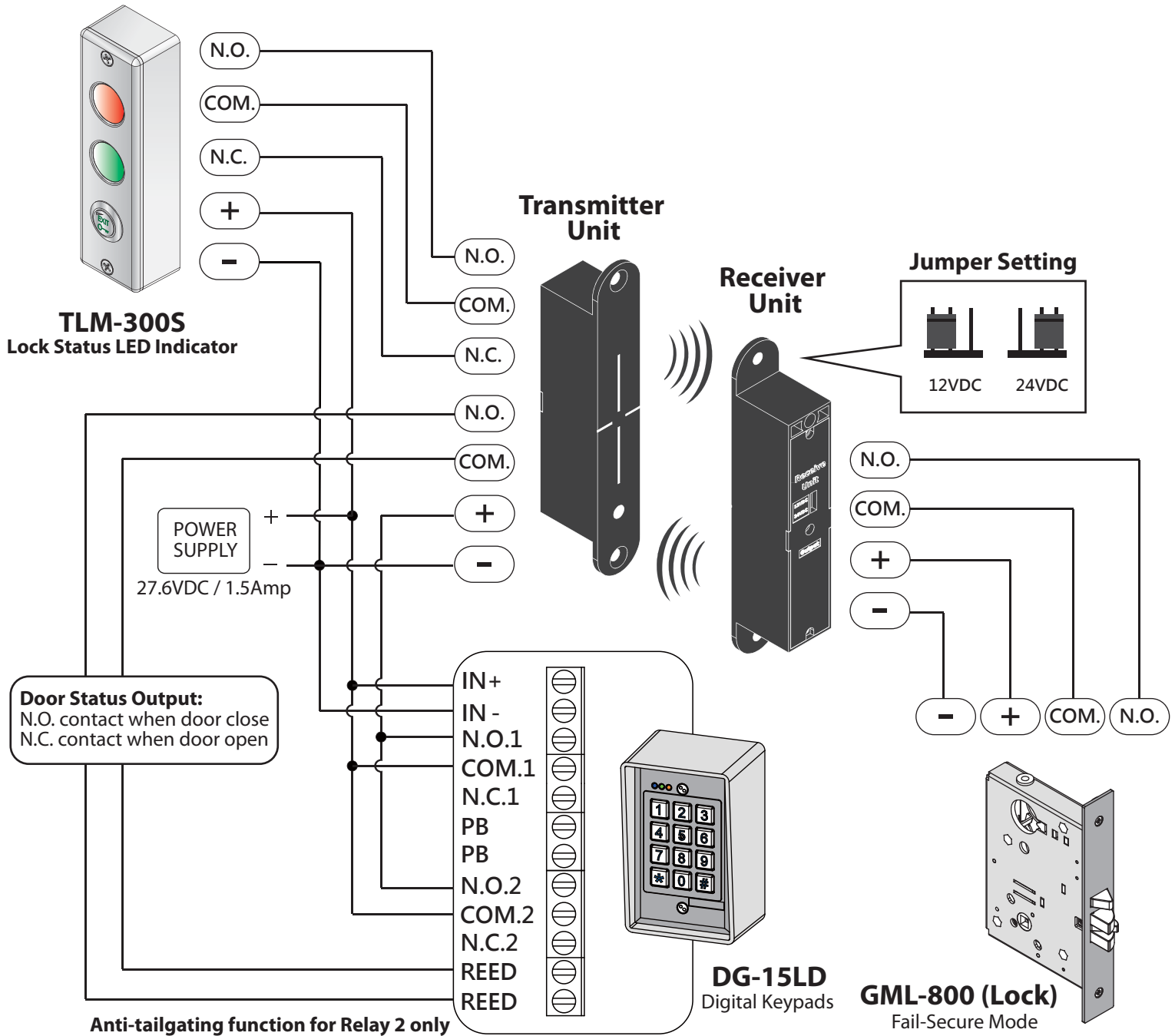

Problem	Possible Cause	Solution
Unable to unlock (Transmitter)	No power	Check that the power supply is connected and works properly Make sure access control relay contact is wired correctly (N.O.) Check jumper settings are correct Check door opening time is not too long (the interval time is 30 seconds)
Insufficient power output (Both)	Installation position is incorrect	Check installation position/alignment is correct Check door gap does not exceed maximum recommended distance (Package including washers for minimizing gap)
No sensor output (Both)	No door status output	Check installation position/alignment is correct
	No lock status output	Check installation position/alignment is correct Make sure lock status wires are connected to wireless power source