

Fig. 1

Spot (4) Holes In Door Stop
for 10-32 Machine Screws or #10 Wood Screws

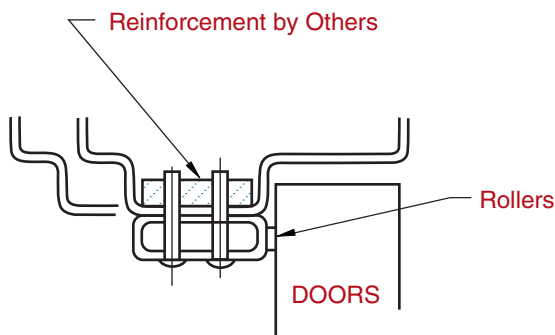

Fig. 2

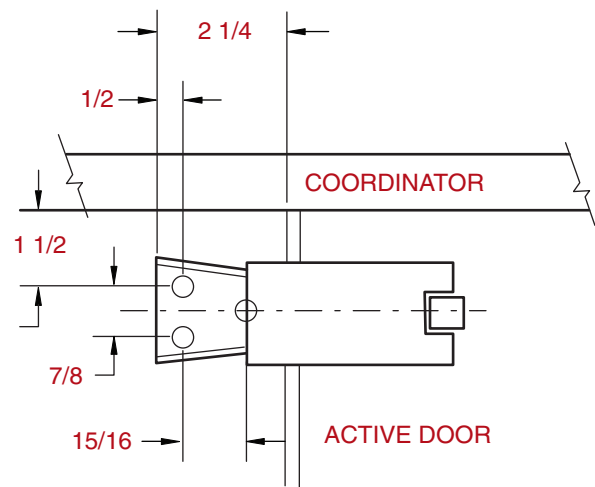

Fig. 3

Drill For (3) 3/8 Dia. Sex Bolts

1. Before spotting holes, inactive (short) arm must be oriented with inactive door prep frame (Fig. 1 & 2).
2. Mount coordinator with (4) 10-32 machine screws or (4) #10 wood screws (Fig. 1).
3. Install carry bar when required (Fig. 3).

Not To Scale

Template No.
T-1700
Rev. 2/10/05

NOTE: Rockwood reserves the right to make product changes and is not responsible for obsolete template errors. To ensure your template is current, please visit our website at www.rockwoodmfg.com or call us at 800-458-2424.